

# CHLORVFS and MULTI POOL CONTROL BOX

## Installation, Operation, and Maintenance Manual

FOR MULTI POOL NEXGEN



## TABLE OF CONTENTS

<b>1.0 DESCRIPTION</b>	<b>3</b>
1.1 General Information	3
1.2 Principals of Operation	3
1.3 General Specifications	4
<b>2.0 INSTALLATION</b>	<b>5</b>
2.1 Unpacking	5
2.2 Storage	5
2.3 Safety Considerations	5
2.4 Plan Ahead	7
2.5 System Diagram	7
2.6 Venturi and Venturi Feed System Installation	9
2.7 Venturi and Venturi Feed System Wiring for One Additional Pool	10
2.8 Five Pool Controller Installation	11
2.9 Five Pool Control Box Wiring	11
2.10 Venturi and Venturi Feed System Wiring for Multiple Pools	11
<b>3.0 USING THE TOUCH SCREEN AND OPERATION THE SYSTEM</b>	<b>14</b>
3.1 The Home Screen	14
3.2 The Menu	14
3.3 Pool / Spa Selection	15
3.4 Test Mode	15
3.5 Outputs	16
3.6 Counters	17
3.7 History	18
3.8 Events	18
3.9 Starting and Operating the System	19
3.10 Flow Rate Information	20
<b>4.0 MAINTENANCE</b>	<b>20</b>
4.1 Cleaning Instructions	20
<b>5.0 WARRANTY INFORMATION</b>	<b>21</b>

Note: This manual is subject to change at any time based on system improvements, design changes, authorized modifications or new information. Please consult ChlorKing for the latest revision.

Manufacturer:  
ChlorKing Inc  
2935 Northeast Parkway  
Atlanta, GA 30360  
1-800-536-8180

# SECTION 1 DESCRIPTION

## 1.1 GENERAL INFORMATION

The ChlorKing® Venturi Chemical Feed System is designed to feed sodium hypochlorite to multiple pools from one NEXGEN. Up to six pools can be chlorinated with one NEXGEN. Each additional pool will require one Venturi Feed System. The system uses a standard venturi coupled to a flow control system and a Multi Pool Control Box controlled by the NEXGEN. The flow control system consists of a flow meter, an actuated valve and a manual flow rate control valve. The system is powered by 120VAC, the NEXGEN and a chemical feed controller capable of providing a 120 VAC control signal. The manual flow rate control valve adjusts to provide any flow of chemical up to the rated amount.

## 1.2 PRINCIPALS OF OPERATION

### Venturi

The venturi is plumbed into the pool circulation system return line. A booster pump provides the flow across the venturi which causes suction at the chemical feed port of the venturi.

### Flow Control System

The flow control system provides a means to control both the duration and quantity of chemical that is fed to the suction of the venturi. The duration of flow is controlled by the actuated valve via a chemical feed controller and the quantity is controlled by the manual flow control valve. The flow control system can control a booster pump for use with the venturi

### Multi Pool Control Box

The Multi Pool Control Box is connected to the NEXGEN, the chemical feed controller, and Venturi Feed System actuated valve. When an additional pool needs sanitizer the chemical feed controller activates the Multi Pool Control Box. The Multi Pool Control Box tells the NEXGEN an additional pool needs sanitizer, the NEXGEN starts and opens the actuated valve, which feeds the pool.

### 1.3 GENERAL SPECIFICATIONS

Model Designation	Sodium Hypochlorite Dose Rate	Rated Pressure	Minimum Water Flow Rate across Venturi	Inlet/Outlet Diameter Venturi	Chemical Feed Diameter
ChlorVFS	Up to 1.3 GPM	30 PSI	30 GPM	1-1/2 inch	1/2 inch

### ELECTRICAL REQUIREMENTS:

Model Designation	Voltage Supply (AC)	Phases	Frequency	Amps
ChlorVFS Power	120	1	60Hz	1
ChlorVFS Controller	120	1	60Hz	1
Multi Pool Control Box	120	1	60Hz	10
Booster Pump	120 to 240 VAC	1	60Hz	Up to 30 amps

**Note: Booster Pump power requirement are based on the rating of the booster pump. The CHLORVFS can control up to 30 amps.**

### DIMENSIONS

ChlorVFS  
L 16" x H 24.5"

Multi Pool Control Box  
L 16" x H 16"

## **SECTION 2 INSTALLATION**

### **2.1 UNPACKING**

Units are shipped from the factory. In the event of damages during shipping, it is the responsibility of the customer to notify the carrier immediately and to file a damage claim. Open the crate or packaging carefully and examine all material inside.

### **2.2 STORAGE**

When storing units, use the original packaging and store under a shelter to protect the contents from weather.

### **2.3 SAFETY CONSIDERATIONS**

**IMPORTANT SAFETY INSTRUCTIONS  
READ AND FOLLOW ALL INSTRUCTIONS**

### **SAVE THESE INSTRUCTIONS**

**WHEN INSTALLING, OPERATING, AND MAINTAINING THIS EQUIPMENT, KEEP SAFETY CONSIDERATIONS FOREMOST. USE PROPER TOOLS, PROTECTIVE CLOTHING, AND EYE PROTECTION WHEN WORKING ON OR INSTALLING THE EQUIPMENT. FOLLOW THE INSTRUCTIONS IN THIS MANUAL AND TAKE ANY ADDITIONAL SAFETY MEASURES APPROPRIATE. BE EXTREMELY CAREFUL IN THE PRESENCE OF HAZARDOUS SUBSTANCES.**

**THE PERSONNEL RESPONSIBLE FOR INSTALLATION, OPERATION, AND MAINTENANCE OF THIS EQUIPMENT MUST BE FULLY FAMILIAR WITH THE CONTENTS OF THIS MANUAL.**

**ANY SERVICING OF THIS EQUIPMENT MUST BE DONE WITH THE UNIT FULLY OFF AND DISCONNECTED FROM THE POWER SOURCE AND ALL PRESSURE BLED FROM THE LIQUID LINES.**

## WARNING

- CONNECT THE EQUIPMENT ASSEMBLY TO A CIRCUIT PROTECTED BY A GROUND-FAULT CIRCUIT-INTERRUPTER.
- ONLY A CERTIFIED TECHNICIAN MAY INSTALL AND SERVICE THE **CHLORKING® VENTURI** SYSTEM.
- MODIFYING THE **CHLORKING® VENTURI** SYSTEM IN ANY WAY MAY CAUSE BODILY INJURY AND WILL VOID THE WARRANTY.
- DO NOT ALLOW CHILDREN TO OPERATE THE **CHLORKING® VENTURI** SYSTEM.
- ONLY REPLACE COMPONENTS WITH THOSE SPECIFIED BY THE MANUFACTURER.
- WHEN INSTALLING THE SYSTEM, ENSURE THAT POWER IS LINKED TO THE MAIN PUMP POWER SOURCE FOR THE POOL TO ENSURE THAT THE **CHLORKING® VENTURI** SYSTEM NEVER OPERATES WHEN THE PUMPS ARE OFF.
- THE SYSTEM HAS THE POTENTIAL TO RELEASE HIGH DOSES OF CHORINE. USE CAUTION WHEN HANDLING, SERVICING, OR OPERATING THE EQUIPMENT.
- CORD CONNECTED AT TIME OF MANUFACTURE
  - DANGER – Risk of injury
    - Replace damaged cord immediately
    - Do not bury cord

## 2.4 PLAN AHEAD

Almost every pump room encountered is different. It is imperative to have prior knowledge of the facility in which the unit is to be installed and to evaluate what type of tools, wall anchors, etc. will be needed to make the installation as problem free as possible.

The Five Pool Controller and Venturi Feed System will need to be installed within 6 feet of a 120 VAC electrical outlet.

## 2.5 SYSTEM DIAGRAM

### One Additional Pool

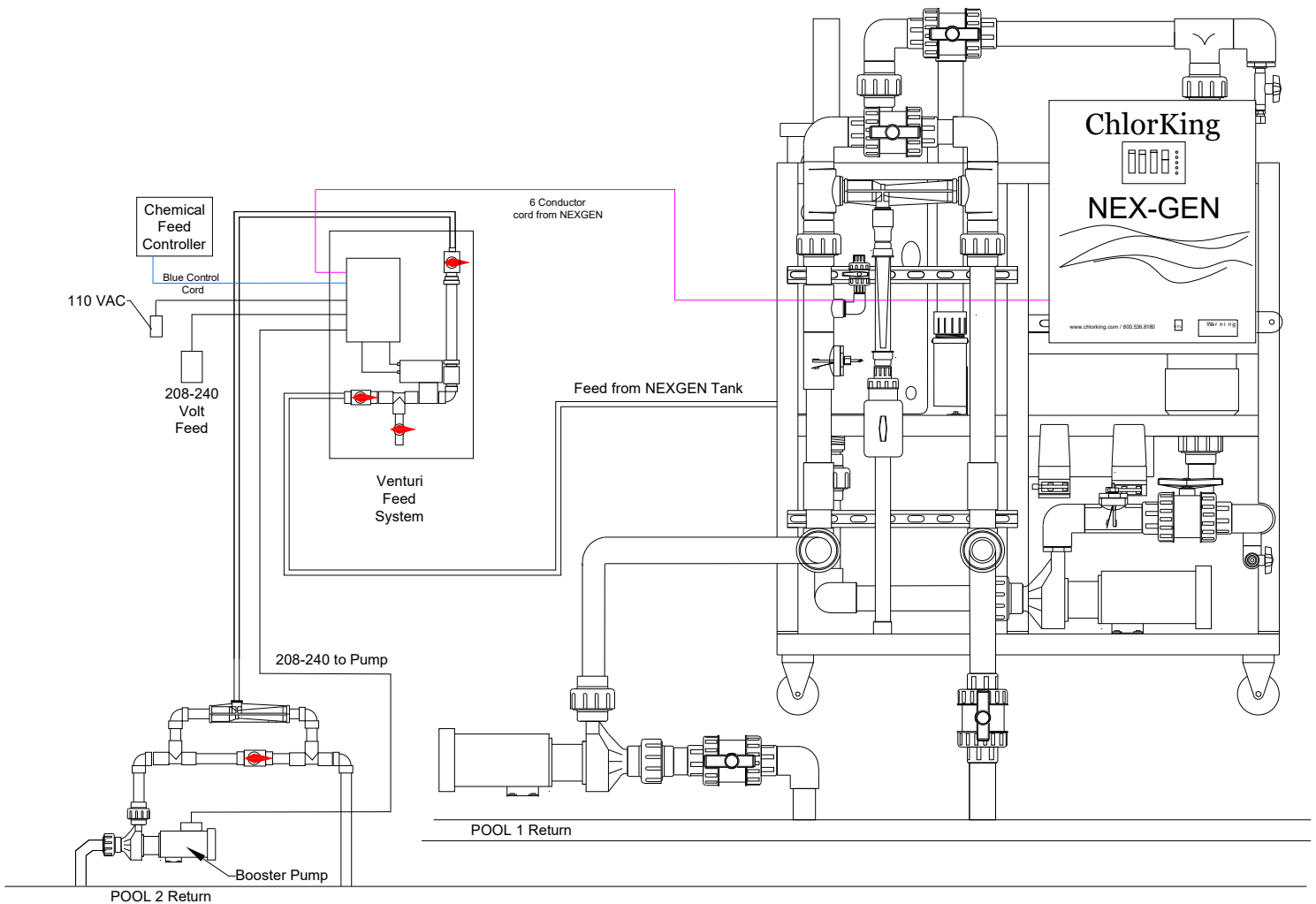

# Multiple Pools

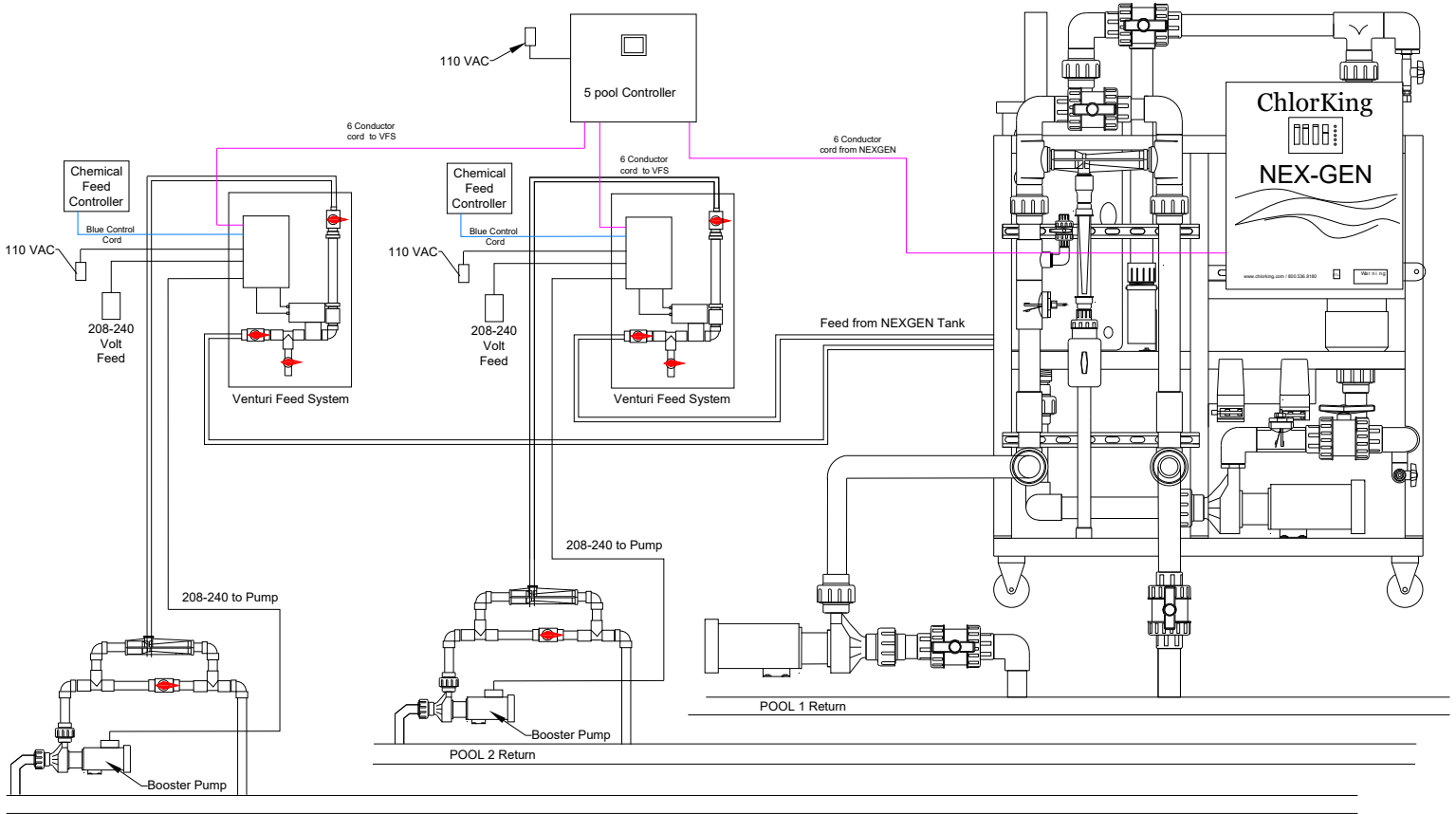



## 2.6 VENTURI and VENTURI FEED SYSTEM INSTALLATION

Each venturi injector requires 30GPM of filtered water to function on pools with up to 25 PSI in the return line. Consult ChlorKing for rates necessary for higher pressures. Use an appropriately sized booster pump to achieve this flow. The venturi should be plumbed as the last component before the water returns to the pool. Plumb the venturi injector with 1-1/2" PVC pipe. For plumbing the line from the NEXGEN production tank through the Venturi Feed System to the venturi injector use 1/2" PP or PE tubing or 1/2" PVC pipe. The Venturi Feed System and NEXGEN production tank are pre-plumbed for use with tubing.

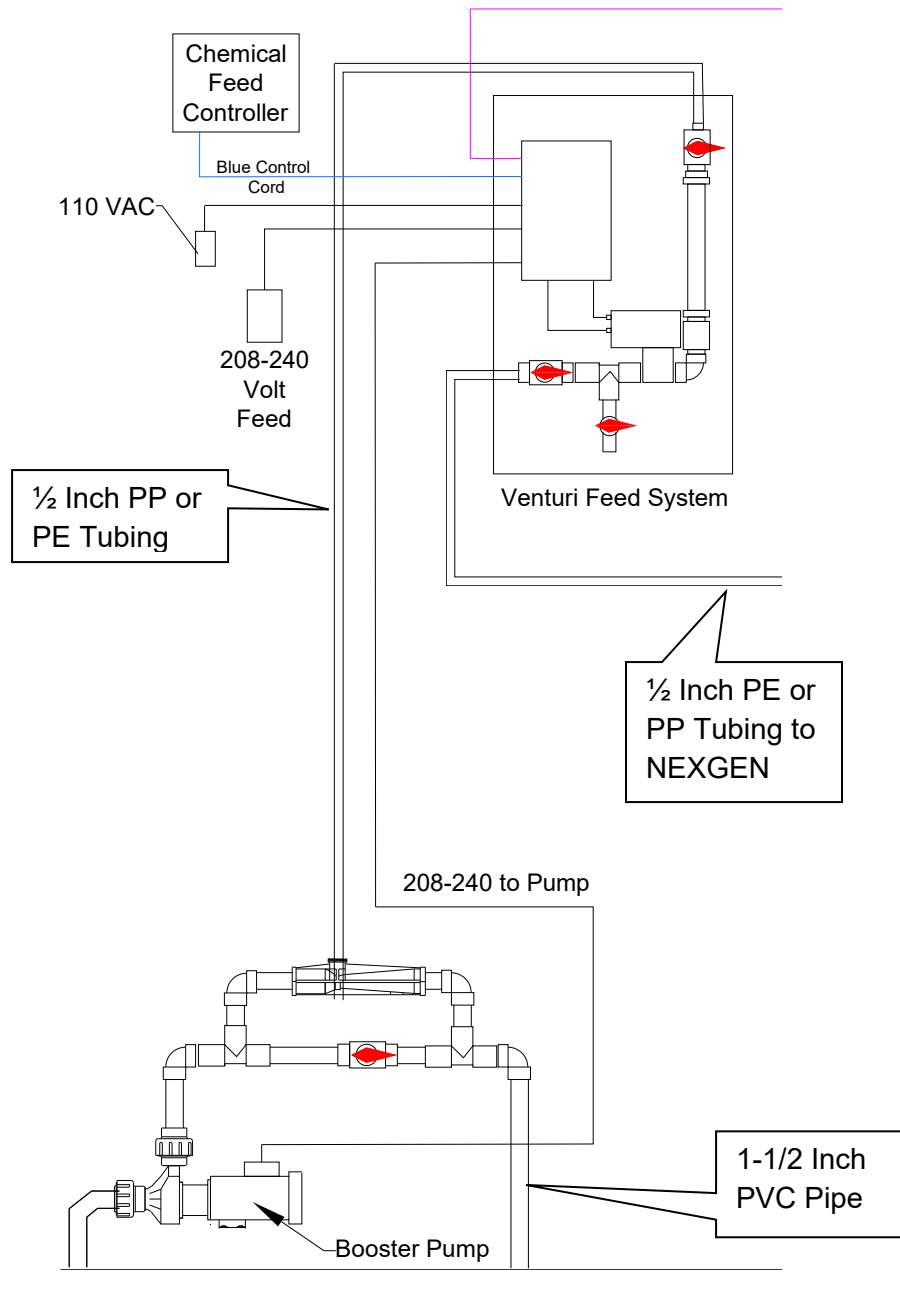

## 2.7 VENTURI and VENTURI FEED SYSTEM WIRING FOR ONE ADDITIONAL POOL

The Venturi Feed System's black power cord plugs into a 15a outlet. The blue control cord plugs into a chemical feed controller.

The Venturi Feed System Control box is equipped with a contactor rated for 240 Vac and 30a capable of controlling the booster pump for the venturi. Wire the contactor as shown below.

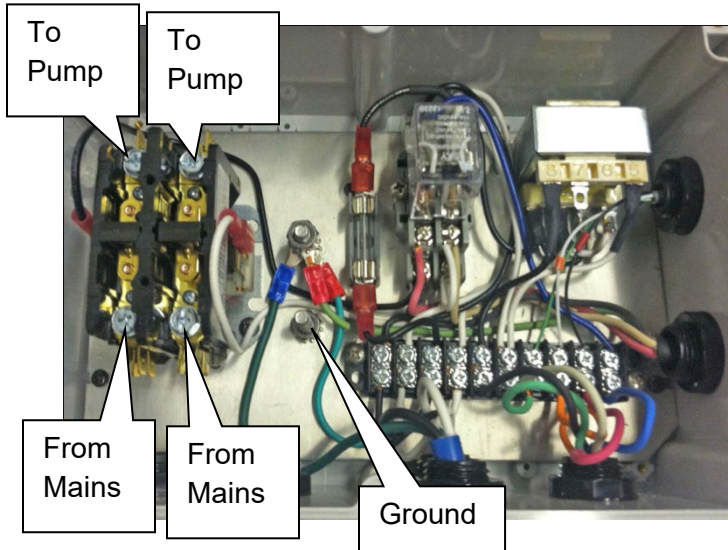

Connect a 6 conductor 18awg SJTOW or SOOW cable (not supplied) from the Venturi Feed System to the NEXGEN.

### CONNECTION DIAGRAM FOR NEXGEN10, 20, 40, AND 80

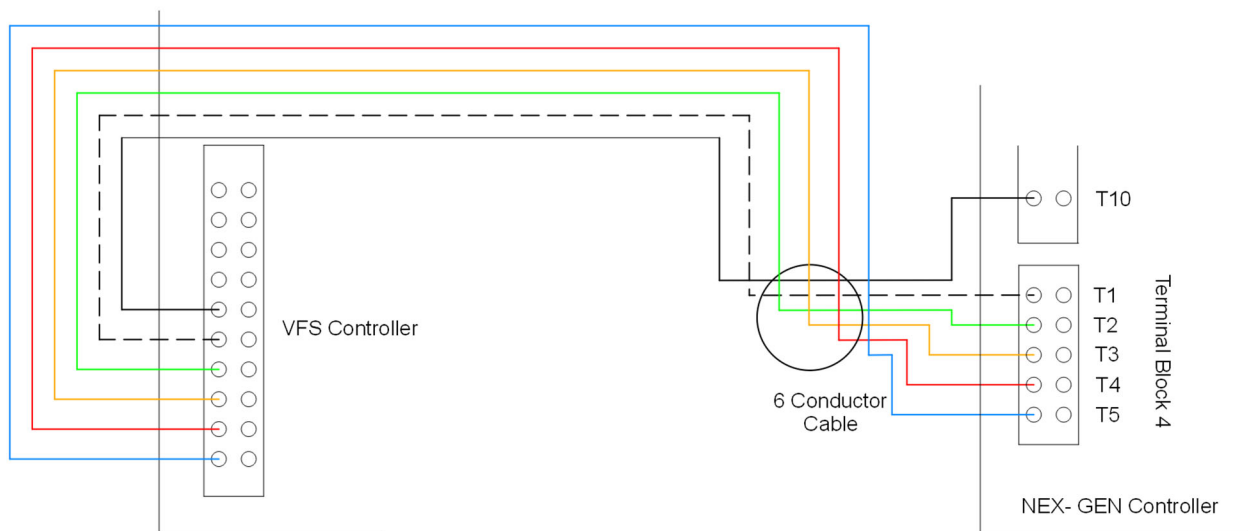

## CONNECTION DIAGRAM FOR NEXGEN50 and 100

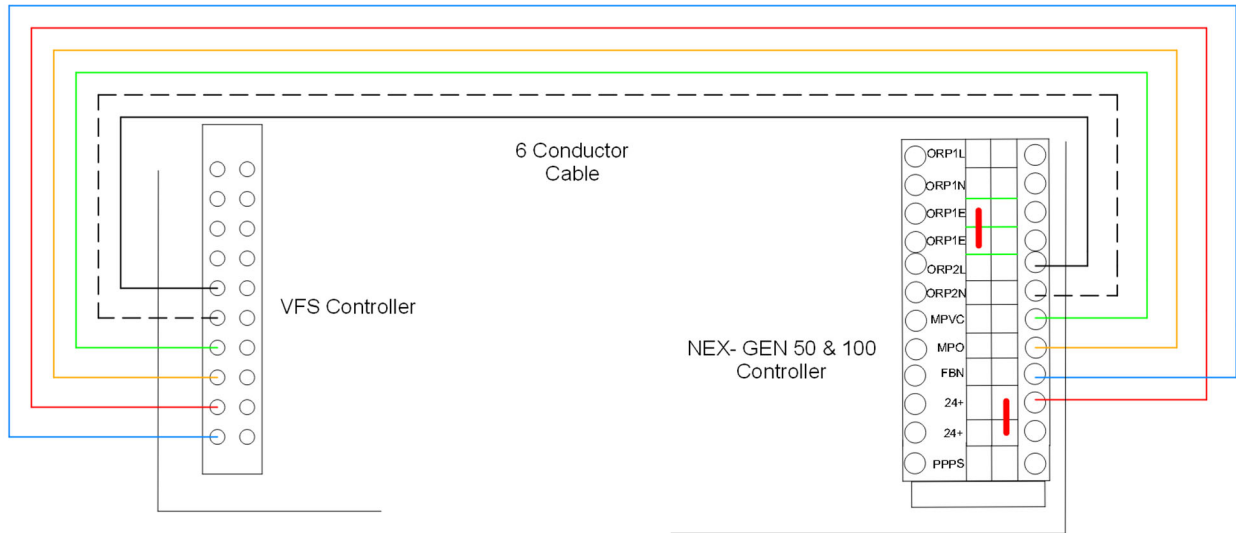

### 2.8 FIVE POOL CONTROLLER INSTALLATION

Locate a space on the wall, in the pump room, that will accommodate the dimensions of the Five Pool Controller. Install in an easy to access location about chest high. Using a level, mark where the box will be located. On a concrete wall installation, mark the wall (using a dot) where the first concrete anchor hole will be drilled. Install the controller directly to the mounting surface.

### 2.9 FIVE POOL CONTROL BOX WIRING

The 5 Pool Control Box has a black power cord that plugs into a 15a outlet.

### 2.10 VENTURI and VENTURI FEED SYSTEM WIRING FOR MULTIPLE POOLS

The Venturi Feed System's black power cord plugs into a 15a outlet. The blue control cord plugs into a chemical feed controller.

The Venturi Feed System Control box is equipped with a contactor rated for 240 Vac and 30a capable of controlling the booster pump for the venturi. Wire the contactor as shown below.

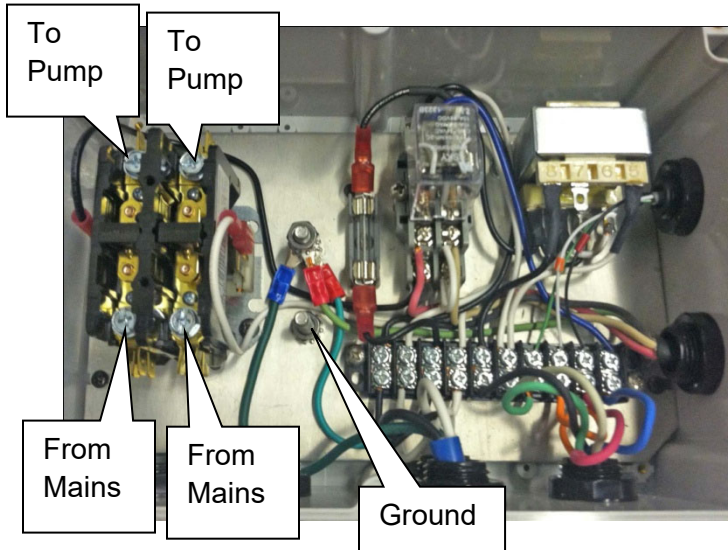

Disconnect power from the NEXGEN, the Venturi Feed System, and the 5 Pool Control Box.

Connect an 18awg, 6 conductor SJTOW or SOOW cable from the terminal block inside of the Venturi Feed System control box to the Pool 2, 3, 4, 5, or 6 Terminal Block inside of the 5 Pool Controller. Repeat this process for all additional pools. Connect an 18awg, 6 conductor cable from the NEXGEN Terminal Block inside of the 5 Pool Controller to the terminal block inside of the NEXGEN for a second pool. See diagram below for NexGen10, 20, 40, and 80. See diagram on the next page for NexGen50 and 100.

### CONNECTION DIAGRAM FOR NEXGEN10, 20, 40, AND 80

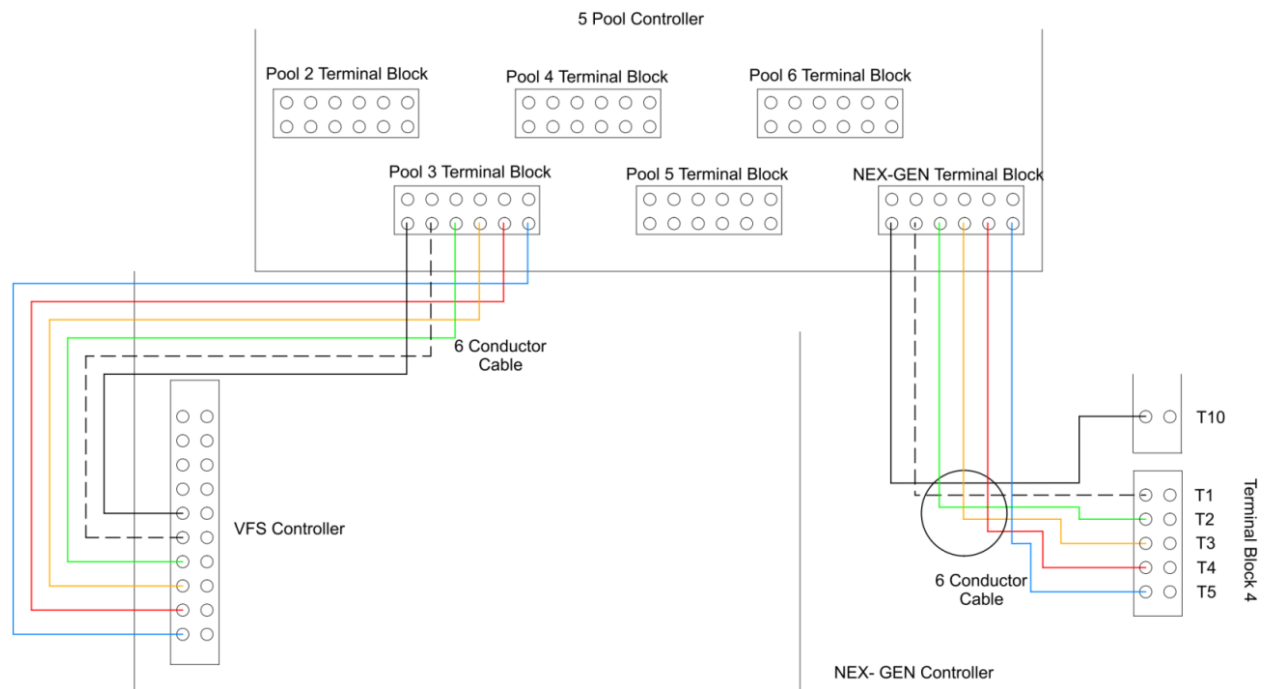

## CONNECTION DIAGRAM FOR NEXGEN50 and 100

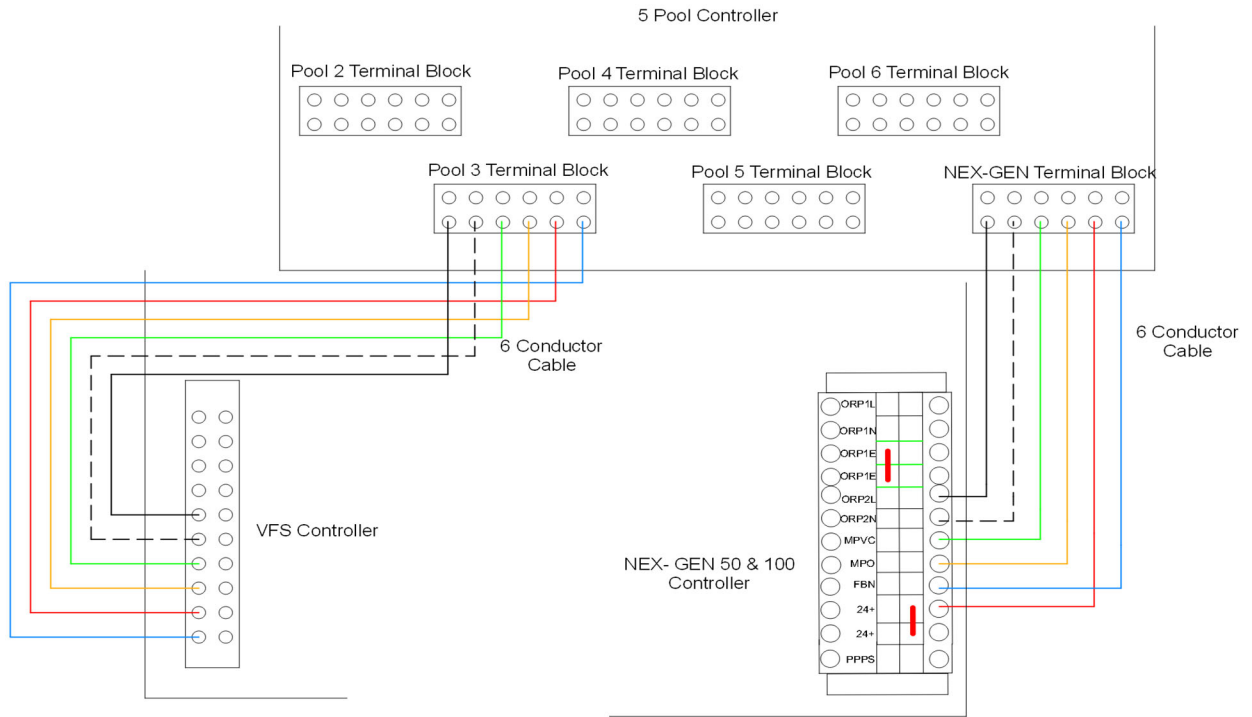

## SECTION 3 USING THE TOUCH SCREEN

### 3.1 THE HOME SCREEN

The HOME screen displays the status of up to 5 additional pools. In this example pool 2, 3, 4, and 6 are active. Pool 5 has been disabled and is not use. Pool 2 and 6 will activate after a one-minute time delay. Pool 3 is on and pool 4 is off. Chemical dosing status is displayed by green and red circles. Green indicates a pool that is being dosed. Red indicates a pool that is not being dosed. The number or letter inside of the green and red circle indicates the input on the microcontroller and is used for troubleshooting.

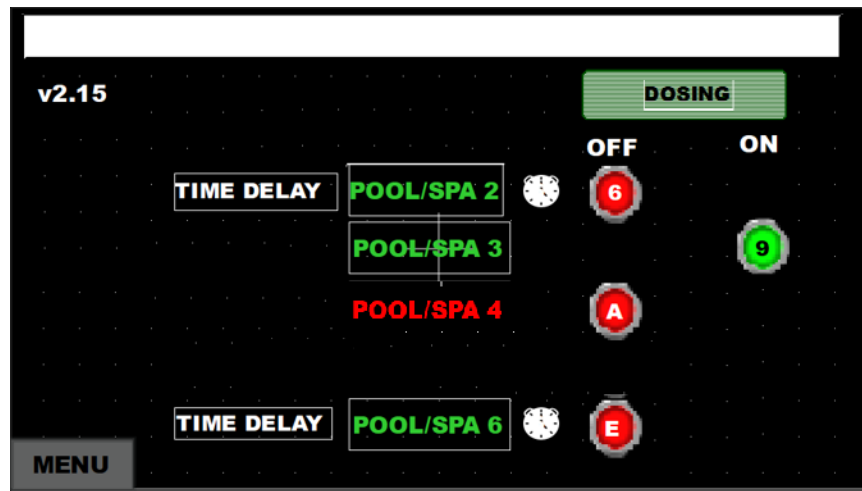

### 3.2 THE MENU

The MENU button is used to access a menu of features, monitors, and settings available in the 5 Pool Control Box. These include Test Mode, Counters, History, Outputs, Pool / Spa Selection, Date / Time, Events, and Easy Access.

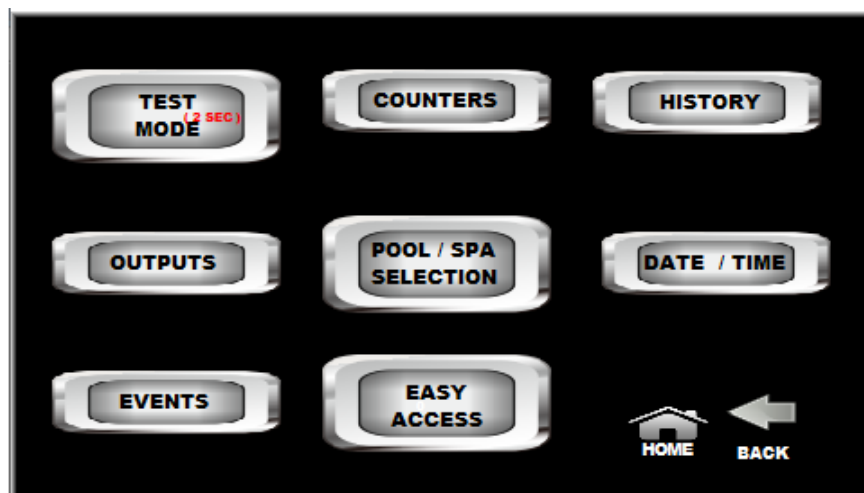

### 3.3 POOL / SPA SELECTION

To select a pool or spa for activation and display on the home screen, press the MENU button then press the POOL / SPA SELECTION button. The screen below will be displayed showing the selection status of pools 2 through 6. A pool or spa shown in **GREEN** has been selected for activation and display on the HOME screen. A pool or spa in **RED** is not activated and will not be shown on the HOME screen. To activate or deactivate a pool or spa, press the button associated with that pool or spa and its status will change from inactive, **RED**, to active, **GREEN**, or from active, **GREEN** to inactive, **RED**.

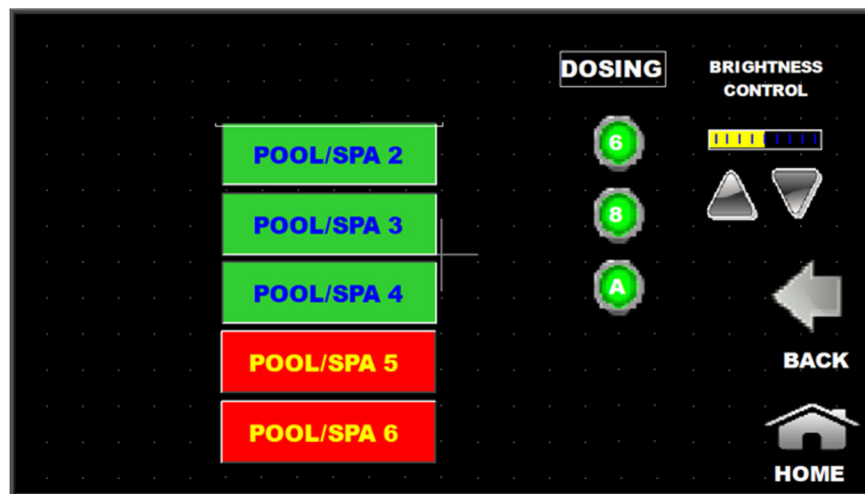

### 3.4 TEST MODE

TEST MODE is used to test, open, or close Venturi Feed System valves manually and test the signal to the NEXGEN. To access TEST MODE from the HOME screen, press MENU then press and hold TEST MODE for 2 seconds. The TEST MODE screen will appear. The NEXGEN system must be on for TEST MODE to function. A NEXGEN that is on will be indicated by a **GREEN** "G". The control signal for the valve under test must also be on. When the control signal is on the Control Signal icon will turn from **RED** to **GREEN**. Once these 2 conditions are met, valves can be operated by pressing the POOL/SPA button desired. When the valve opens, the **RED** dosing icon will move to the next column and turn **GREEN**. To test the additional pool request to the NEXGEN, press the **RED** NEXGEN OFF button. The button should turn **GREEN**. The NEXGEN should respond by displaying the Feeding Pool 2 Icon.

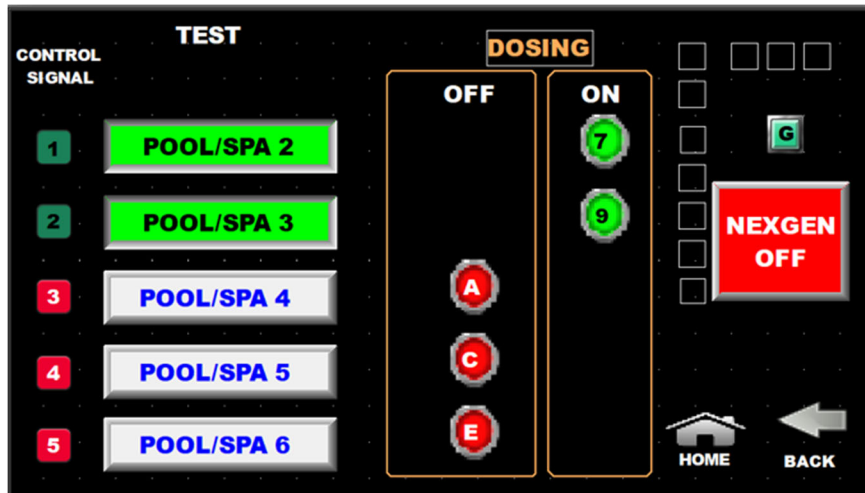

### 3.5 OUTPUTS

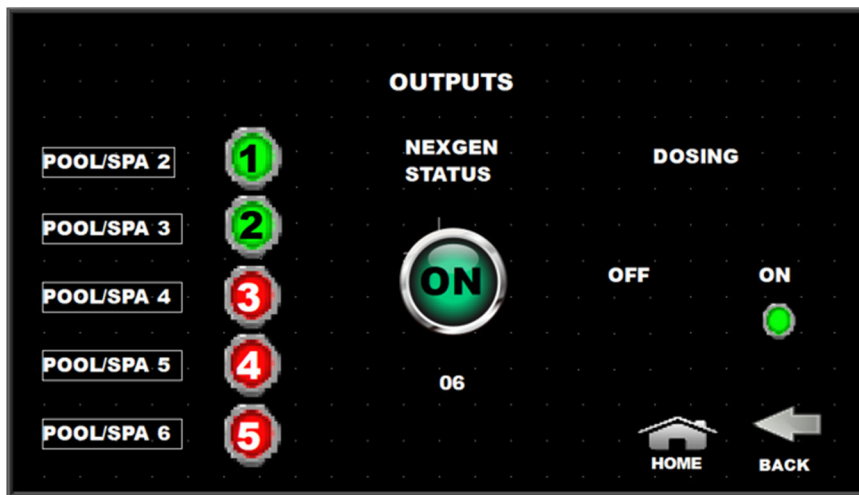

Active and inactive OUTPUTS can be viewed by pressing MENU then OUTPUTS from the HOME screen.







### 3.6 COUNTERS

The COUNTER screen tracks the total and daily run time and number of feed cycles for each pool. To access the COUNTERS screen, press MENU then COUNTERS from the HOME screen. To reset a counter, press RESET and select the Pool / Spa you wish to reset.

	TOTAL RUN TIME	DAILY RUN TIME	DOSING CYCLES	
<b>POOL/SPA 2</b>	##### hr	#### min	####	 HOME
<b>POOL/SPA 3</b>	##### hr	#### min	####	 RESET
<b>POOL/SPA 4</b>	##### hr	#### min	####	
<b>POOL/SPA 5</b>	##### hr	#### min	####	
<b>POOL/SPA 6</b>	##### hr	#### min	####	 BACK

RESET COUNTER	TOTAL RUN TIME	DOSING CYCLES	
<b>POOL/SPA 2</b>	##### hr	####	 BACK
<b>POOL/SPA 3</b>	##### hr	####	
<b>POOL/SPA 4</b>	##### hr	####	 HOME
<b>POOL/SPA 5</b>	##### hr	####	
<b>POOL/SPA 6</b>	##### hr	####	

### 3.7 HISTORY

The HISTORY for each pool can be accessed from the HOME screen by pressing MENU then HISTORY and then selecting the pools HISTORY that is of interest. The HISTORY screen contains every event by date.



### 3.8 EVENTS

The EVENT screen records events that are system faults. The screen is also used to reset a fault or alarm. To access the EVENT, press MENU, EVENTS.

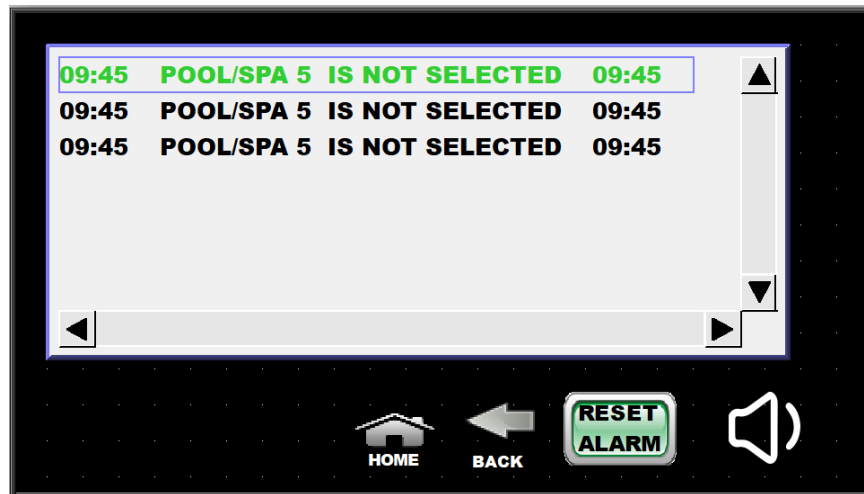

### 3.9 STARTING AND OPERATING THE SYSTEM

Confirm that the Chemical Feed Valve is open, and the Service Valve is closed. Open the chemical flow control valve all the way. Activate the valve by plugging the blue cord into an outlet or by activating the feed function on the chemical feed controller. Ensure that the flow meter will flow more than the desired flow rate of product. Adjust the flow control valve for the desired rate (See Flow Rate Information under Section 3.10). Flow is read at the top of the orange float.

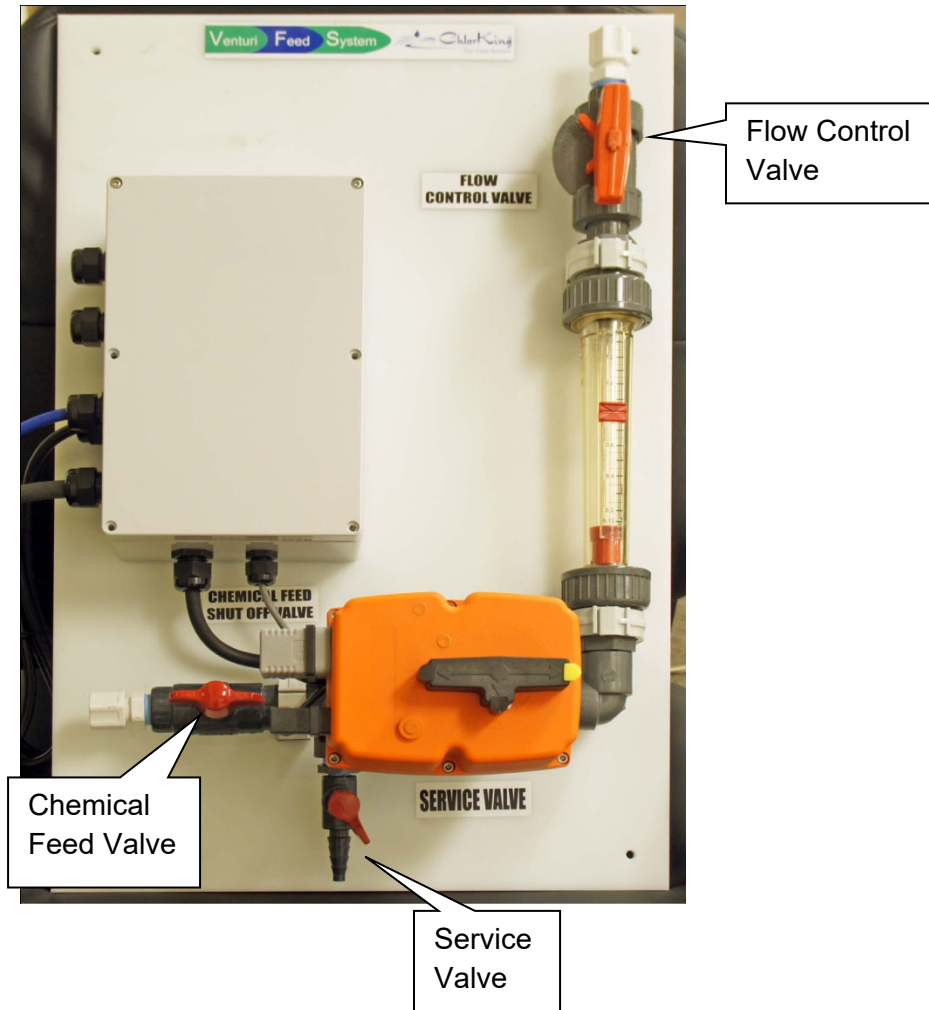

### 3.10 FLOW RATE INFORMATION

NEX-GEN 10 = .5GPM

NEX-GEN 20 = 1GPM

NEX-GEN 40 = 2GPM

NEX-GEN 80 = 4GPM

The total flow through the NEXGEN plus all active Venturi Feed Systems cannot exceed the total rated flow of the NEXGEN. For example, a NEXGEN 20 has a total flow rate of 1GPM. The NEXGEN can be adjusted to .5GPM and each of 2 Venturi Feed Systems can be adjusted to .25GPM each for a total flow of 1GPM.  $.5 + .25 + .25 = 1\text{GPM}$

## SECTION 4 MAINTENANCE

The ChlorKing Venturi Feed System will need to be cleaned on a routine basis. The frequency of cleaning is determined by the type and quantity of sodium hypochlorite fed through the system. As a rule, the unit will need to be cleaned if flow rates drop from the initial values.

### WARNING

**Failure to follow the cleaning instructions exactly as written may result in damage to equipment or injury to persons.**

#### 4.1 CLEANING INSTRUCTIONS

Shut the chemical feed valve. Attach the service valve to a bucket of fresh water and open the service valve. Activate the valve from the touch screen (Section 3.2, Manual Mode) and flush all sodium hypochlorite from the system. Once all sodium hypochlorite has been flushed from the system, attach the service valve to a dilute (10:1) solution of muriatic acid. Flush the system for several seconds. Reattach the service valve to a bucket of fresh water and flush all muriatic acid from the system. Close the service valve and open the chemical feed valve. Readjust the flow with the flow control valve to the desired level.

## **SECTION 5 WARRANTY INFORMATION**

The ChlorKing® Venturi Feed System carries a limited 1-year warranty

During the warranty period the customer shall return the defective component, freight prepaid, accompanied by the original invoice or proof of purchase, and ChlorKing® shall at its sole discretion elect to repair or replace the defective component and return it to the customer, freight pre-paid.

ChlorKing® accepts no responsibility other than to repair or replace a defective component, and this warranty specifically excludes product failure due to accidental damage, abuse, misuse, and negligence, damage due to non-compliance of the operating manual or unauthorized alterations or modifications to the system. ChlorKing® accepts no responsibility and is not liable for any extended warranties or variations to this warranty offered by re-sellers of ChlorKing® systems.



## Warranty Registration Card

Please complete and return to activate ChlorKing® warranty  
Please mail or fax to ChlorKing® inc. P.O. Box 80823, Atlanta, GA, 30366 Fax: 770-685-6576

Dealer Name: \_\_\_\_\_

Address: \_\_\_\_\_ City: \_\_\_\_\_

State: \_\_\_\_\_ Zip: \_\_\_\_\_ Tel: \_\_\_\_\_

Installation site of equipment: \_\_\_\_\_

Address: \_\_\_\_\_ City: \_\_\_\_\_

State: \_\_\_\_\_ Zip: \_\_\_\_\_

Date of purchase: \_\_\_\_\_ Serial number: \_\_\_\_\_

1. Pool size: \_\_\_\_\_ 2. Pool finish: \_\_\_\_\_

3. Indoor / Outdoor: \_\_\_\_\_ 4. Heated: Yes / no

5. Filter Type: \_\_\_\_\_ 6. Pool Age: \_\_\_\_\_

7. New or existing pool: \_\_\_\_\_ 7. Controller installed: Yes / No

8. If controller installed, what make and model: \_\_\_\_\_